

# 产品尺寸图 (DIMENSION)

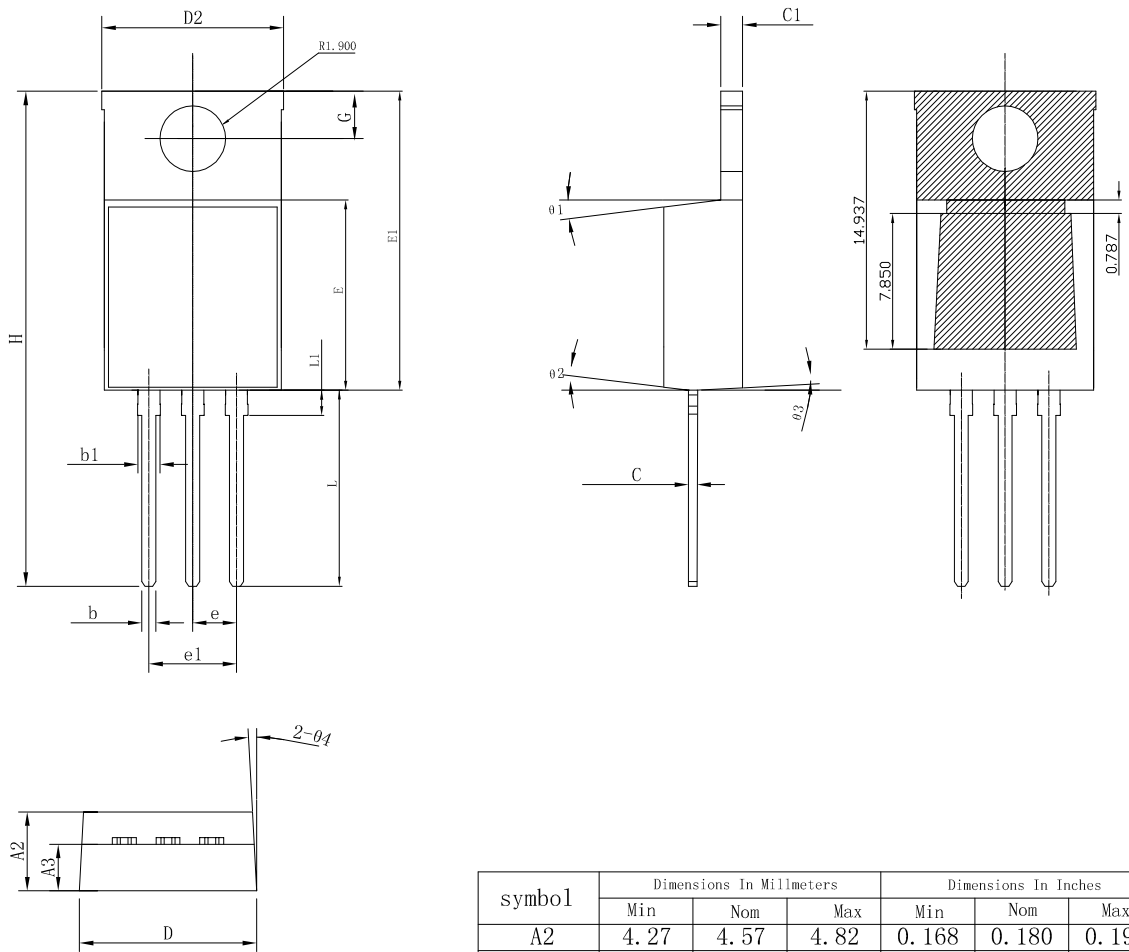

symbol	Dimensions In Millimeters			Dimensions In Inches		
	Min	Nom	Max	Min	Nom	Max
A2	4.27	4.57	4.82	0.168	0.180	0.190
A3	2.54	2.70	2.80	0.100	0.106	0.110
b	0.75	0.81	0.95	0.029	0.032	0.037
b1	1.27	1.37	1.47	0.045	0.050	0.055
C	0.40	0.50	0.60	0.016	0.020	0.024
C1	1.15	1.27	1.39	0.045	0.050	0.055
D	9.66	10.16	10.28	0.380	0.400	0.405
D2	10.06	10.26	10.46	0.396	0.404	0.412
E	10.83	11.03	11.23	0.405	0.412	0.420
e	2.42	2.54	2.66	0.095	0.100	0.105
E1	17.13	17.33	17.53	0.653	0.660	0.668
e1	4.83	5.08	5.33	0.190	0.200	0.210
G	2.54	2.74	2.94	0.100	0.108	0.116
H	28.4	28.68	28.9	1.118	1.129	1.138
0 1	—	7°	—	—	7°	—
0 2	—	7°	—	—	7°	—
0 3	—	3°	—	—	3°	—
0 4	—	3°	—	—	3°	—
L	11.15	11.35	11.55	0.461	0.469	0.477
L1	1.36	1.46	1.56	0.054	0.057	0.061

# FSMC

图名 NAME	T0-230		图号 DWG. NO.	DD0052-A	SH 1 OF 1
材质 MATERIAL	Cu		REV.	A	
单位 UNITS	mm [INCH]	核准 APPROVE	审核 CHECKED	制图 DRAWN	 第三角法
日期 DATE	2012.03.30				
比例 SCALE	N. T. S.				